

STAR

St. Tammany Ancestral Roots

The Quarterly Newsletter of the
St. Tammany Genealogical Society

P. O. Box 1904
Covington, LA 70434-1904

Web site: www.StTammanyGS.org

Vol. XIX No. 3 & 4 Sept. & Dec. 2007
DOUBLE ISSUE



President: Martha I. Dutsch
Newsletter Editor: Robert B. Noles

**St. Tammany Parish,
Louisiana**

St. Tammany Genealogical Society

The Genealogical Society for
St. Tammany Parish, Louisiana

St. Tammany Ancestral Roots (The STAR) is published quarterly in March, June, September and December. Letters to the editor, comments, suggestions and inquiries to be included in the STAR should be addressed to the Editor. The deadline for items to be included in the STAR is two weeks prior to the first of the month for the month of publication.

INSIDE THIS ISSUE

Census Taker's Home, The	20
Committees	16
DNA Testing for American Indian Ancestry	21
Dues Schedule	25
Family Tree Maker - 2008	22
Genealogy Books for Kids	26
Genealogy Junky	17
Life in the 1500s	18
Lifetime, A; Then the Will	12
Lost Colony Symposium	29
Member Roster	4, 5 & 6
Meeting Schedule	24
Mission & Goals	25
New Members	7
North American Local and County Histories Go Online	10
Reference Material (For Sale)	19
Should We Call It Genealogy or Family History ?	15
Smolenyak, Megan in Mandeville June 21, 2008	8
St. Tammany Parish History	31
STGS Committees	16
Viva La Louisiane !!!	28



PRESIDENT'S LETTER

October 1, 2007

Dear Members & Friends,

Once again, the STGS Newsletter is being published as a double issue. This is partially due to the lingering impact of Katrina, but also because we don't have enough new extracted research material and/or genealogies ready to publish. Once again, I plead with you to submit articles of interest for the STGS Newsletter.

Starting with this issue of the STAR, a complete listing of members is included (see pages 4, 5 and 6 in this issue).



Since Hurricane Katrina, attendance at STGS meetings and participation in STGS volunteer efforts has been way down. In an attempt to increase participation in Society activities, the regular meetings are being switched from the second Tuesday of the month (1:30 PM to 3:30 PM) to the second Saturday of the month (10:00 AM to Noon). The new schedule will be effective in 2008, starting with the January 13, 2008 meeting. The STGS meetings will continue to be held in the Covington Branch Library meeting room. I hope to see you there.

Come to the STGS meetings in Covington on Saturdays and make a day of it at the STPL Genealogy Resource Center now managed by Al Barron. If you haven't seen the genealogy resources at the Covington Library recently, you are in for a big surprise. Hundreds of new books and CD-ROMs have been added to the Covington collection just in the past few months.

Rob Noles has arranged for Megan Smolenyak, genealogy author and lecturer and the chief family historian for Ancestry.com to be in Mandeville for an all day seminar on Saturday, June 21, 2008 (see page 8 for more information). Please make your plans early for attendance at this special event for the Mandeville / Covington area.

Elaine Boston has accepted an appointment to be both the Program and Publicity Chairman for the STGS. Thanks Elaine for filling these two positions for the Society.

Membership dues for 2008 are now being accepted. Please note that the cost of Life Memberships have been reduced.

As usual, if you have suggestions or comments concerning the STGS or this newsletter, please let me know.

Martha J. Dutsch, STGS President



2007 STGS MEMBERSHIP ROSTER

MEMBERSHIP		NAME		EMAIL
NO.	TYPE	MEMBER	SPOUSE	
378	Individual	ABERCRROMBIE, Linda		linda2991@cs.com
062L	Life	ALLARD, Myriam		No Email Address
369	Library	ALLEN County Public Library		mclclegg@acpl.info
150	Individual	ANDRY, Bernice L.		No Email Address
403	Individual	BECK, Nancy House		wandbeck@bellsouth.net
390	Family	BOSTON, Lawrence A.	Elaine	lboston@bellsouth.net
412	Individual	BOUDREAUX, Lauran Charbonnet		No Email Address
382	Individual	BRAGG, Gerald A.		gerryandcheryl@bellsouth.net
105L	Life	BROUSSARD, David		rdbroussard@bellsouth.net
379	Individual	CASTELLANOS, Lance	Carolyn	No Email Address
152L	Life	CLEMENTS, Gloria		No Email Address
402	Individual	COLLINS, John C.		john1297@cox.net
313	Individual	CONNER, Juanita Rimare		ncbc@bellsouth.net
372	Individual	COUSINS, Melissa Perret		missy_cousin@yahoo.com
406	Individual	CUROLE, Jesse J.		jjchpc@alo.com
401	Individual	DAVIDSON, Elizabeth		lizabeth2646@bellsouth.net
380	Individual	DEINKEN, Peter H.		pdeinken@charter.net
134L	Individual	DUTSCH, Martha Ives		dutschm@netzero.net
318	Individual	EPP, Arthur J., Jr.		aapp@grandecom.net
093L	Life	FAVROT, Manette S.		No Email Address
286	Individual	GASPARD, Levy Joseph "Joe"		stgs0325@medeldev.com
409	Individual	GAUDET, Hazel Corkern		hazelgaudet@bellsouth.net
340	Family	GEIGER, Sam	Carol	samandcarolg@yahoo.com
367	Individual	GOODWIN, Karol P.		kappygoodwin@yahoo.com
408	Individual	HARDENSTEIN, Howard J.		hardensteinh@bellsouth.net
301L	Life	HARPER, Thomas & Helen		hetharp@bellsouth.net
253	Individual	HARRY, Fran W.		jafra@i-55.com
229	Individual	HERMAN, Mary Jean		mjherman@bellsouth.net
009L	Life	HOLDEN, Doris E. Martin		demh1@bellsouth.net



2007 STGS MEMBERSHIP ROSTER (Cont.)

MEMBERSHIP		NAME		EMAIL
NO.	TYPE	MEMBER	SPOUSE	
086H	Honorary	HUGHES, Thomas E.		sevenup@wt.net
020L	Life	JOHNSTON, Nellie		No Email Address
089L	Life	KEEN, Lorraine L.		lorraine154@juno.com
292	Individual	KISER, James, Dr.		2thdr1@bellsouth.net
404	Family	KRUBBE, James	Dorothy	jkruebbe@i-55.com
335	Family	KULLMAN, Bobby	Russell	rocky3hills@datastar.net
320	Individual	LeBLANC, Elwood J.		ejleblanc_915@charter.net
054L	Life	LEMONS, Jack		No Email Address
341L	Life	MacDOUGALL, Doug		rdglsmacdougall@aol.com
376	Individual	MARTIN, Sheila Lilia		sheilam78@comcast.net
365	Individual	McMANUS, Barbara		bem17@hotmail.com
375L	Life	McMURRY, Thomas		ole_tom_99@yahoo.com >
370	Individual	McVEAN, Deborah E.		demcvean@ticnet.com
360	Individual	MEYER, Carol Raley		raleymer@bellsouth.net
394	Individual	MIDDLETON, Donald		don-ald.middleton@sdhc.k12.fl.us
241	Individual	MORGAN, Marvin D. C.		No Email Address
407	Individual	NAKAMURA, Kathy		janepualani@hotmail.com
233	Individual	NOLES, Robert B.		rbnoles@bellsouth.net
322	Family	OLSEN, Wade R.	Carolyn S.	wolsen@bellsouth.net
252	Individual	PADGITT, Barbara Carter		bpadgitt@houston.rr.com
139L	Life	PAUL, Ione		impaul1@bellsouth.net
411	Individual	PERKINS, Della Rose		drperkins@i-55.com
351	Individual	PICHON, LeRoy		rainmaker501@yahoo.com
338	Individual	REED, Richard C.		reed2425@bellsouth.net
265	Individual	RIECKE, Karen Smith		ksriecke@bellsouth.net
384	Individual	ROME, Alfred J., Jr.		walkingf@bellsouth.net
405	Individual	ROOF, Don		donroof@kansas.net
413	Individual	RUBACH, Jerry Ann		computerchick@yahoo.com
184L	Life	RYAN, Doris R.	Gus	drryan@bellsouth.net



2007 STGS MEMBERSHIP ROSTER (Cont.)

MEMBERSHIP		NAME		EMAIL
NO.	TYPE	MEMBER	SPOUSE	
325	Individual	SHERLOCK, Gerald W.		sherlocksell-
410	Library	ST. TAMMANY PARISH LIBRARY		alb@stpl.us
142	Individual	STANGA, Gaye Lynn		glstanga@bellsouth.net
304	Individual	STEPAN, Roberta R.		rstepan@bellsouth.net
396	Family	WILKIN, Charles R.	Elsie Ann	crwilkin@bellsouth.net
371	Individual	WILLIAMS, Carolyn		carowms@bellsouth.net
048L	Life	ZARINSKI, Sally Simmons		sallyzarinski@bellsouth.net

MEMBERSHIP ROSTER

Please let the Editor of the STAR (rboles@bellsouth.net or 985-845-4688) know if your listing in the Membership Roster is incorrect.

PLEASE NOTE DUES FOR 2008 ARE NOW DUE

The dues for 2008 remain the same as for 2007 for all membership classifications, except for Lifetime Memberships, which have been reduced. See the STGS dues schedule on page 25 in this newsletter.

The Society requests that you complete a membership application/renewal form (available via www.StTammanyGS.org) or from any STGS officer. Please send the Application/Renewal Form with your check to the STGS address provided on the application form, or turn in your form at a regular meeting.

Thank You for Your Support



STGS NEW MEMBERS

The following people, families or organizations have become members of the St. Tammany Genealogical Society since the last newsletter. Please take a moment to welcome a new member at the next regular meeting or by sending them a note or an email.

NEW MEMBERS & CORRECTIONS

409 GAUDET, Hazel Corkern

(spelling correction)

411 PERKINS, Della Rose

(not reported previously)



NOTICE

The opinions, articles, and statements expressed herein are solely for the use of STGS members. Neither the reviews nor the reports may be used in advertising or for any commercial purpose. STGS and the authors disclaim any liability, loss or risk, personal or otherwise, that is or may be incurred as a consequence, directly or indirectly, of the use and application of any of the products, techniques, and technologies mentioned herein. STGS does not imply endorsement of any outside advertisers or other vendors appearing in these pages.

SURNAMES

Just as a reminder, please be aware that the STGS is developing a Surname Database; i.e., a card file listing your name and the names of the surnames you are researching, plus the pertinent information concerning your research. Please contact Carol Meyer (raleymeyer@charter.net) (985-898-6348) to obtain blank surname cards or to see if other current or past STGS members have identified surnames of interest to you.

Thomas Family is Washington Parish Fair Family

The Charles Morris Thomas and Elizabeth (Betsy) Richardson Thomas family will be featured as the Washington Parish Genealogy and History Society exhibit in the Armory Building during the Washington Parish Fair in October according to Fran W. Harry, president of the Society.

Charles Morris and Betsy Thomas have hundreds, if not thousands, of descendants who remain in this area. Charles Morris settled in Washington Parish while his younger brother, Leroy Thomas, settled in St. Tammany Parish and left many descendants in the area also.

This will be a very interesting exhibit and the family needs volunteers to help at the exhibit and visit with relatives that come by. If you are related to this prominent family, please call to see how you can assist with this project. You may call Dr. Jerry and Lou Ann Thomas at 735-1800, Tina Thomas at 848-9955 or Eloise Thomas at 848-5264.



MEGAN SMOLENYAK SMOLENYAK

In Mandeville June 21, 2008

Megan Smolenyak Smolenyak, the Chief Genealogist for Ancestry.com, author, and genealogy lecturer will be in Mandeville for a series of five presentations on Saturday, June 21, 2008. This event is jointly sponsored by the Knowles/Knoles/Noles Family Association and the STGS.

Megan Smolenyak Smolenyak (yes, that's her real name), author of *Honoring Our Ancestors* (Inspiring Stories of the Quest for Our Roots), *In Search of Our Ancestors* (101 Inspiring Stories of Serendipity and Connection in Rediscovering Our Family History), *Tracing Your Roots with DNA* (Using genetic tests to explore your family tree) and *They Came to America* (Finding Your Immigrant Ancestors), has been an avid genealogist since the



6th grade and is skilled in many aspects of family history research.

Megan is honored to serve as Chief Family Historian and North American spokesperson for Ancestry.com, the largest genealogical company in the world. She is also co-founder of Roots Television, a pioneering and popular online channel of genealogy and history-oriented programming. Among the many shows available for viewing is the New York City press conference about Annie Moore, where Megan corrected history by revealing the true story of the first immigrant through Ellis Island. This story was featured on the front page of *The New York Times* and in a variety of other publications, such as the *Irish Echo*, *Time for Kids*, and *The Wall Street Journal*. The story was also covered by NPR's *Morning Edition*, PBS's *Out of Ireland*, and numerous other TV and radio shows. More recently, she made another interesting Irish connection when she traced a branch of Barack Obama's family to Moneygall in County Offaly.

Megan also made news when she discovered a startling connection when requested by Austin Fenner of the *New York Daily News* to research the roots of Rev. Al Sharpton. Much to her astonishment, she learned that Rev. Sharpton's great-grandfather had been owned by relatives of Strom Thurmond.

After Megan walked Rev. Sharpton through his family tree, she traveled with him to Edgefield, SC to see first-hand the plantation and slave quarters (still standing) where his family had lived and the slave cemetery where some of his family is likely buried.

Trace Your Roots with DNA: Using Genetic Tests to Explore Your Family Tree, her latest book (co-authored with Ann Turner, M.D.), has been featured in *Newsweek*, *The New York Times*, on NPR, and in the Book of the Month Club.

Megan has appeared on Good Morning America (featured in roots segments on Diane Sawyer, Robin Roberts, Chris Cuomo and Sam Champion), the *Today Show*, CNN, *BBC Breakfast*, *Ancestors*, *Time-Watch*, NPR, BBC Radio and a number of local television and radio shows, and has spoken at the National Genealogical Society, Federation of Genealogical Societies, Who Do You Think You Are LIVE! and numerous other genealogical, historical, military, ethnic and literary events (21 states, Washington, D.C., England, Canada and Mexico so far!).

As lead researcher for the PBS *Ancestors* series, she delved into over 5,000 genealogical stories and developed much of the content for the companion website. She has subsequently consulted for other television programs, including *They Came to America* and *African American Lives* for PBS, and BBC's *Timewatch* (regarding the identification of sailors' remains recovered from the *USS Monitor*). Since 2000, Megan has also been a consultant with the U.S. Army's Repatriation project to trace families of servicemen killed or MIA in Korea, WWII and

See Smolenyak (Continued on page 9)



NORTH AMERICAN LOCAL AND COUNTY HISTORIES TO GO ONLINE Announced by FamilySearch.org - August 15, 2007

Three genealogical libraries pool their collections in massive digitization effort

SALT LAKE CITY, UTAH—Thousands of published family histories, city and county histories, historic city directories, and related records are coming to the Internet. The Allen County Public Library (ACPL) in Fort Wayne, Indiana, Brigham Young University Harold B. Lee Library, and FamilySearch's Family History Library in Salt Lake City announced the joint project today. When complete, it will be the most comprehensive collection of city and county histories on the Web—and access will be free at:

www.familyhistoryarchive.byu.edu

The digital history project will target over 100,000 published family histories and thousands of local histories that are rich in names as well as biographical and genealogical data associated with those names. "Publishing those collections from the three libraries involved will make a significant and attractive family history digital library online for genealogists and historians," said David Rencher, director of Records and Information for FamilySearch.

"I believe the most immediate, substantial contribution of this collaboration will be the addition of local history materials," said Allen County Public Library's Genealogy Center Manager, Curt Witcher. The collaborative project will digitally scan thousands of historic city directories, as well as city and county histories from North America. The ACPL and the Family History Library have the largest collections of city and county histories from North America. "I believe the strength of our two well known,



well used, and well loved institutions working together is a terrific benefit to the genealogical community," added Witcher.

Once digitized, the collections will have "every word" search capability, which allows users to search by name, location, date, or other field across the collection. The search results are then linked to high quality digital images of the original publication. Digitization efforts have begun. New additions will be noted and hyperlinked in the Family History Library Catalog at FamilySearch.org as they are digitized. The collection can be accessed currently at:

www.familyhistoryarchive.byu.edu

FamilySearch is providing the computers, scanners, and camera operators required to complete the project. FamilySearch is a nonprofit organization sponsored by The Church of Jesus Christ of Latter-day Saints. FamilySearch maintains the world's largest repository of genealogical resources accessed through FamilySearch.org, the Family History Library in Salt Lake City, and over 4,500 family history centers in 70 countries.





REPORTERS NEEDED

The STAR could use your help! Please submit your genealogy related articles to the Editor for possible publication in the STAR. Topics could be any of the following:

- General Interest Genealogy Articles
- Extractions - St. Tammany Area Sources
- STGS Business (Committee Reports)
- Sickness & Death Notices (STGS members)
- Queries
- Pedigree Charts or Descendant Charts
- Library Activities or Content
- Former STGS Officer Information
- Your Personal Genealogy Success Story
- Your Personal Genealogy Enigmas
- Historical Figure Connections
- Reunion Announcements
- Book Reviews
- Software Reviews and Recommendations
- Washington Parish Activities
- Plug Your Genealogy Book / Research
- Identify Favorite Web Sites
- Genealogy Humor
- Unusual Genealogy Findings
- Your use of DNA Testing to Supplement Your Genealogical research

FIELD TRIPS



The next STGS field trip is tentatively scheduled for August 2008. This field trip will be a return trip to Baton Rouge for a visit to the East Baton Rouge Parish Bluebonnet Library and the Louisiana State Archives or to the Jefferson Parish Library.

The last field trip was in January 2005 to the East Baton Rouge Parish Bluebonnet Library and the Louisiana State Archives in Baton Rouge.

Transportation for STGS field trips is by private vehicle. Members interested in car pooling to the field trip destinations are to meet between 7:45 and 8:00 AM in the parking lot directly behind the Shell station in front of the Office Depot / Books-A-Million stores off Hwy. 190 in Covington. The members taking these field trips usually plan on a full day at the libraries, returning by about 5:00 PM.

Contact Martha I. Dutsch or Robert B. Noles if you have questions, suggestions or comments about future field trips.

PLEASE NOTE

The Genealogical Society does **not** do family research via volunteers or for hire, but we will be glad to list your queries in this newsletter or on the Society's web page as space is available.

Contact Martha Dutsch (985-892-6561) if you want a recommendation for someone to hire to do genealogical research in St. Tammany Parish (or the surrounding areas) for you.



A LIFETIME; THEN THE WILL

By Lance Castellanos

Hilaire Boutté was born in Mobile, North America. He was one of five brothers. This was a time in History when the English, French and Spanish were vying for possession of territory in the New World.

His father, Andre Claude Boutté, came to Ft. Conde, in Mobile, as a young soldier, from Bouseville in the old province of Picardie, France. He eventually married in 1746 to Marie Anne Bodin. Her parents were Captain Nicolas Bodin and Francoise Palie. By 1750, Hilaire's father had completed his military duty and was discharged. Hilaire was born in 1753 and the family lived in Mobile until 1763. It was that year the Treaty of Paris was drawn up which gave England all the territory east of the Mississippi River, with the exception of New Orleans.

When the French flag was lowered over Mobile for the last time in 1763, Andre Claude, Hilaire's Father, had to choose between abandoning his land or living under English Protestant rule. Having heard of the "ethnic cleansing" of the Acadian population by the English, Andre Claude decided to move to French-speaking, Spanish-ruled Louisiana. Hilaire was about ten years old when his family arrived in New Orleans from Mobile. About seven years later he was listed in a 1770 militia census, living on St. Anne St., house No. 12, along with brothers Francois, Philip and Antoine. His age was 17 yrs. old, his profession, along with his brothers, was blacksmith. That would seem fitting, as boys usually followed into the profession of their father. Their father, Andre Claude was the King's locksmith, at Ft. Conde (everybody worked for the King). As a locksmith he would also have been a blacksmith.

As blacksmiths they probably made carriage and wagon parts, horseshoes, door and gate hinges, nails and metal straps for house and building construction. This work may have lead to Hilaire's profession which we will soon see in his will.



As stated by Samuel Wilson, "Among the many interesting testaments recorded in bound will books in the office of the clerk of the Civil District Court in New Orleans is that of the late eighteenth and early nineteenth century architect – builder, Hilaire Boutté. It is to be found in Will Book No. 1, folio 197 and in the Notarial Records of Pedro Pedesclaux, the notary by whom it was recorded on November 25, 1808."

The will of Hilaire Boutté, translated from French:

I Louis Hilaire Boutté, inhabitant of this city of New Orleans, being sick but sound of mind, fearing death, I dictate and cause to be written my testament and order of my last will as follows:

1st. I declare to be the legitimate son of Claude Boutté and of Marianne Baudin, both deceased.

2nd. I declare to be of the Catholic apostolic and Roman religion and as such I believe in God to whom I recommend my soul and after my death I wish to be buried in the place intended for Roman Catholics, leaving to the disposition of my testamentary executors, whom I shall hereafter name, the ceremonies of my burial and funeral.

3rd. I declare to be a bachelor.

4th. I declare that Mr. Jn. Bt. Degruy is in partnership with me in the undertaking that I have made by contract with the Navigation Company for the pass from Bayou St. John to Lake Pontchartrain. That I have not yet settled any account with him relative to this undertaking.

5th. I declare that in my papers will be found several notes agreed to by Mr. J. B. Degruy and that all those which are anterior to the year eighteen hundred are of no value.

See Boutté Will (Continued on page 13)



Boutté Will (Continued from page 12)



6th. I declare to owe to Rosette Jung, by note, a sum of two thousand five hundred fifty three dollars and besides, that of eight hundred, of which I have made no recognition, which she loaned me. I having borrowed from Mr. Matzinguir in this amount, which two sums I wish might be paid to her after my death by my testamentary executors.

7th. I declare that said Rosette Jung has an acknowledgment from me which states that the negress Catherine with her three children, Louise, Cocote & Coffi, as well as the little negro girl Jeanne, are her property for the reason stated in the said acknowledgment, which I approve and ratify and I order that after my death, there might be furnished by my testamentary executors a title in form of the ownership of the said slaves stating in it that I have received payment for them.

8th. I declare that the above said Rosette Jung has made the sale to me in the month of March, eighteen hundred six, of two lots situated in Roy St, the one bounded by the house of Mr. Pavie and by the Bank of Louisiana and the other by those of Mr. Tricou and of Mad'l. Wd. Thomassin; that for the value of these lots I have paid nothing to the said Rosette, and that she made this sale to me only in order to oblige me and providing me the means of giving a mortgage in favor of the Navigation Company for security of the accomplishment of my contract with it. In consequence I order that in case the mortgage should be lifted, the specified two lots might be remitted to her in the condition in which they are found, as being her property, and in the contrary case, the value of the said lots might be paid to her, from the proceeds of my estate and in preference to all other creditors, since I was obligated towards her by private signature papers that I furnished to her the twenty one October of the said year, eighteen hundred six.

9th. I declare that I have a quite old account with Mr. Montegut, Doctor, for the treatment of my household and for the works that I have done for his account

and I order my testamentary executors to liquidate it.

10th. I declare to owe to the heirs of my brother Antoine Boutté the sum of eleven hundred dollars that he loaned me at different times.

11th. I declare that jointly with Mr. Jn. Bte. Degruy, we owe to the heirs of my late brother Antoine a sum of six hundred dollars for the work of the said deceased in our undertaking for the Bayou St. John pass, and besides, a sum of fourteen hundred dollars as indemnity for a negress and a negro that the said deceased lost in our service & similarly that we owe by halves four hundred dollars to each of the two children of my brother Antoine, Henri & Leon, for their salaries acquired in the works of the here above mentioned enterprise.

12th. I declare that I have some accounts to settle with Messrs. Fr's Duplessis, Seuseneau, & Robelot the total of which it is impossible for me to fix, and I order my testamentary executors to liquidate it.

13th. I declare to owe to several workmen and that Mr. Ls. Boisdoré, as in charge of my works, will designate the persons and the sums that are due to them and that similarly I owe to the said Sieur Boisdoré, without being able to designate what sum that he will himself indicate.

14th. I declare to owe several persons through notes & I order that my testamentary executors should acquit all those that are presented to them that are recognized by them as legitimate.

15th. I declare that I have an old account to settle with Mr. N'l Fortier who owes me, due for final payment, a sum of around a thousand dollars and that I am charged with paying into his hands a note of my brother Antoine for around six or several hundred dollars, of which he is the bearer.

16th. I declare that Mad's Wd. Sespedes owes me a sum of six hundred dollars for final payment for the house that I constructed for her and besides, the

See Boutté Will (Continued on page 14)



Bou t  Will (Continued from page 13)



amount of the estimate that will be made of the addition that I made for her house. That similarly there is due me more than fifteen dollars by Mr. Guille-
mard for final payment for the building of his house situated at the corner of

Royal & Orleans streets, & four hundred sixty dol-
lars by Mr. Paul Darcantel, sixty of which for his ac-
count and four hundred that he is charged to pay me
for Mr. Faisandieu, on account of which I have re-
ceived only a little money and a few thousands of
bricks.

17th. I declare to be interested by half in the land
presently occupied by Baptiste my brother to whom
the other half belongs, not withstanding that it had
been bought in my own name, and I give and be-
queath the said half to the children of my late brother
Antoine.

18th. I declare not to have made any enumeration of
my estate because it is well known to my testamen-
tary executors.

19th. I give and bequeath to Rosette Jung my furni-
ture, my dishes, my silverware, my table and body
linen, my beds and my kitchen utensils as well as my
cabriolet with its horse.

20th. I give and bequeath to Adilaide, daughter of
Rosette Jung one fifth of the clear value of all my
estate.

21st. I institute and name my testamentary executors
with seizing and without having to furnish any bond.
Messrs Joseph Villemon LeBlanc & Js. Souli  to
whom I give power and faculty as ample as required
by law so that without any intervention of Justice
they will be able to take possession of my estate after
my death, making the inventory, estimate and sale of
it, liquidating my succession and remitting the resi-
due to my heirs, and in order to fulfill my will, I give
them one year and even more if they should have
need of it.

22nd. I institute and name for my sole and universal
heirs my three brothers, Francois Cesar, Philippe &
Baptiste Bou t  and the children of my late brother
Antoine Bou t , to the end that all my estate might be
enjoyed after my death by the said Francois Cesar,
Philippe and Baptiste each for one fourth and the
children of Antoine, the other fourth.

I revoke and annul any other testament, codicil or
power for testament anterior to this one and I wish
that they might be annulled and that the present
might be entirely accomplished as being the decree
of my last wishes. Done at New Orleans, the twenty
five November, eighteen hundred and eight.

Hilaire Bou t 

Hilaire Bou t 's will gives us some interesting infor-
mation on other projects he had undertaken in later
years. Some works done by Bou t  include the
building at the corner of St. Peter and Chartres
streets, now part of LePetit Theatre du Vieux Carr 
contracted around 1795. Bou t  also did some work
on the St. Louis Cathedral in 1799 and work on the
jail cells behind the Cabildo in 1801. In 1803 and
1804 he built houses for Almonester's widow at St.
Anne and Chartres and St. Anne and Decatur where
her daughter was later to build the Pontalba build-
ings. A contract he made with the Navigation Com-
pany for the pass from Bayou St. John to Lake
Pontchartrain. The house Bou t  built for Vincent
Rillieux's widow is very likely the old house on
Bayou St. John, known as "Pitot House" for it was
sold by the widow Rillieux to James Pitot on April 3,
1810. Bou t 's will seems to indicate that it was
built for Madame Rillieux's daughter, Marie Celeste,
who married Germain Masson and their daughter,
Celestine, was the mother of the noted French artist,
Edgar Degas.

Hilaire Bou t  is the ancestor of STGS member,
Lance Castellanos. Thanks to Lance for providing
such an interesting document for publication in the
STAR.



SHOULD WE CALL IT GENEALOGY OR FAMILY HISTORY?

by James M. Beidler

This article from the Lebanon, Pennsylvania Daily News came with a warning label:

CAUTION: Philosophy ahead (Do not operate heavy machinery after reading this column).

Especially in the last few decades as ancestor hunting has become a mass sport, so to say, there has been a debate inside and outside the so-called genealogical community (that is, professionals, societies, libraries and other organizations) on what we should call ourselves.

Should we stick with the traditional term “genealogist” — which, strictly defined, is the study of bloodline ancestors — or use the broader term “family historian”?

While I’ll admit to using the terms somewhat interchangeably, there is a philosophical difference that is not insignificant.

For one example, would we want to omit adoptees from the genealogies that are compiled? True enough, these folks do not share the bloodline, but they share the experience of life with their adopted families.

And, in these days of “open” adoption as well as more reunions with birthparents, it makes sense to me that adoptees “belong” in both families — one by blood, the other by physical bonding.

No one should have to choose one or another family when he or she can be part of both.

As another example, with the introduction of DNA into genealogy, not a few lineages that previously relied on the “paper proof” of documents all of a sudden crumbled. Every so often one even hears of a story about DNA proving that someone who has been the Number 1 researcher in a family isn’t re-

lated by blood via what is delicately termed a “non-paternity event (NPE).”

Note: there was a paternity event; it was just mis-identified.

These individuals sometimes are emotionally disenfranchised — even feeling like an imposter — in the families that they’ve lived in.

But using the phrase “family historian” instead puts these people back in the game, since here we are talking about the people who lived together, supported each other (and, yes, probably fought with each other, as families also do).

Of course, this whole thing can be expanded further. When I recently spent a week as an adult chaperone for a church youth mission trip, I felt the “crew” of teens that I spent the week with were like a family — even telling one of the boys that if I had a son, I’d want the kid to be like him.

Perhaps we have a lot of different “families” in a lifetime.

That’s probably taking the concept a little too far. But I think it’s fair to say that even when we use the word “genealogy” today, we’re no longer using it in that strict way of bloodline-only.

Using the phrase “family history” shows that it’s more than genes that make a family.



The Genealogist’s Dream City Block

STGS Committees

Committee/Project	Chairperson	Assignment	Status
Advertising & Affiliates	Robert B. Noles		on-going
Ancestor Database	Robert B. Noles	Carol Meyer	on-going
Books & CDs Advice & Procurement)	Robert B. Noles		on-going
Christmas Luncheon	Martha I. Dutsch	Carol Meyer	on-going
Computer / Internet Genealogy - Training	Robert B. Noles		on-going
ERC Coordination & Genealogy Open House at STPL	Robert B. Noles		on-going
Family Tree Maker - Training	Robert B. Noles		on-going
FGS Representative	Robert B. Noles		on-going
Flowers & Cards (Sunshine Person)	Nellie Johnston		on-going
Forms, Signs, Flyers, etc.	Robert B. Noles		on-going
Funeral Home Records - Book / CD	Robert B. Noles	Carol Meyer	on-going
Genealogy 101 - Training	Robert B. Noles		on-going
Genetic Genealogy	Robert B. Noles		on-going
Incorporation & IRS 501(c)(3)	Robert B. Noles		Completed
Membership Communications	Robert B. Noles		on-going
Multi Society Genealogy Seminars	Martha I. Dutsch		on-going
Neff Files	Robert B. Noles	Carol Meyer	started
Newsletter Editor	Robert B. Noles		on-going
NGS Representative	Robert B. Noles		on-going
Officer Installation			on-going
Pedigree Project	Robert B. Noles	Carol Meyer	on-going
Photography	Gerald A. Bragg		on-going
Picture CD (St. Tammany Ancestors)			future
Program & Speakers	Elaine Boston		on-going
Publicity	Elaine Boston		on-going
Reception & Registration	Gerald A. Bragg		on-going
School Genealogy Project	Martha I. Dutsch		new effort
Slidell Contact	Roberta R. Stepan		on-going
STPL Coordination	Martha I. Dutsch		on-going
STPL Volunteer Program			on-going
Surname Cards	Robert B. Noles	Carol Meyer	on-going
Webmaster	Robert B. Noles		on-going



GENEALOGY JUNKY

By Linda Jean Shepherd, Ph.D.

I'm a genealogical junky. It's mystifying, since my family never interested me. I was a scientist immersed in the physical world until the spirits of my ancestors demanded I find them. While other family members are delighted when I share what I've discovered, I'm the only addict in the family. I revel as the name of each new ancestor finds a resonance and place in my body. Knowing them, I feel different inside.

What lures homebodies like me on journeys across the globe in search of gravestones, wills, and church records? What is it about genealogy that makes normal people become obsessed, compelled to discover our ancestors' names? Addiction to genealogy is such a common affliction that online stores sell t-shirts proclaiming "Genealogy Addict." Helpful websites list the symptoms:

- You would rather read census schedules than a good book.
- Your idea of a great vacation is visiting cemeteries and historical societies.
- You have traced every one of your ancestral lines back to Adam and Eve, have it documented, and still don't want to quit.

I knew I was hooked when I found myself tracing the genealogy of the Maine Coon cat we inherited.



The Church of Jesus Christ of Latter-day Saints has tapped into the mysterious force that causes genealogical addiction and woven it into the fabric of its theology. They consider genealogical data collection a religious duty. In China, people compete to update genealogies burned by the Red Guard during the Cultural Revolution. Genealogy was so im-

portant to the Maori of New Zealand that they symbolically inscribed it in the form of moko (tattoos) on their bodies with an albatross's wing bone.

As I discover more about my forbears' lives, I better understand the emotional and psychological patterns that have been passed down to me alongside my DNA. I've always been haunted by a sense of deprivation, which contrasts sharply with my comfortable material circumstances. I even thought I had no family left, other than my brother. That feeling of deprivation makes more sense, now that I know something about my ancestors' cumulative poverty and struggles: Irish potato famine immigrants; a great-grandmother who lost four children due to undernourishment; and an emaciated, half-blind uncle who was killed robbing a bank.

Now that I'm aware of the origin of certain beliefs and behaviors, I can release old dysfunctional patterns and make new choices. And as I heal my sense of deprivation, I imagine the healing passing to my relatives along the lines of time.

Through genealogy, I've discovered an abundance of family, including a second cousin, an only child of an only child, who believed she had no blood relatives left in the world. When I reunited her with two flesh-and-blood second cousins and a history of our family, she thanked me for "the best, most important gift" she'd ever received.

Genealogy creates webs of connection. The more I discover about my ancestors, the more of humanity I include in my family and the less justification I have for prejudice and intolerance. With each new name, the connections multiply—through time and space—linking me to bygone families as well as present-day cousins across the globe. Every family is woven into the tapestry of humankind, and understanding it gives me a larger perspective. Any vista of time can be reinterpreted when seen from another perspective. New visions of past,

See Genealogy Junky (Continued on page 18)



Genealogy Junky (Continued from page 17)

present, and future events create alternative routes to explore, expand, and heal.

I have the sense that what I learn in my life reverberates through time and impacts the souls of my ancestors as well as the descendents of our bloodline. Beneath all the cataloging of names and dates, there is something numinous about reweaving this web of family.

Some people derive a deep sense of interconnectedness with the universe through the revelations of quantum physics; I find it through my ancestors. Experiencing synchronicities and help from ancestors opens me to questioning the nature of reality. Where do my ancestors reside? Are the spiritual realms in other dimensions? What is the nature of time? What's the purpose of life? At a deep level, my addiction to genealogy is an expression of my innate desire for connection—to myself, to family, to humanity, to spiritual realms, and to the Creation.

I'm proud to be a genealogy junky, and I savor the delicious rush from each new discovery. Fortunately, I still have many more ancestral lines to trace before reaching Adam and Eve.

Editor's Note: I didn't write this article, but I could have for it describes me pretty well. As Garfield (the cat) would say, "I resemble that remark."



A Genealogist's Dream Town

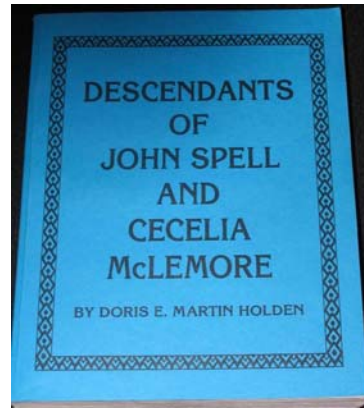

The excellent book, *Descendants of John Spell and Cecelia McLemore* by Doris Holden is available for sale again. Hurry to get your copy while the supply lasts.

\$40 + postage

Doris Holden

Telephone No: 985-892-1611

Email: demh1@bellsouth.net

**Address: 74509 Woodland Road,
Abita Springs 70420**

LIFE IN THE 1500s

In the March/June issue of the STAR, the Editor included an article entitled "Life in the 1500s." This was an entertaining article about life in the 1500s that provided 'plausible' reasons for a number of popular sayings we use today; e.g., "don't throw out the baby with the bathwater", "it's raining cats and dogs", "he was a dead ringer", etc.

The editor failed to identify the article as fiction. Only one person sent an email to the editor indicating the true nature of the article. If you would like to read about the true nature of the sayings allegedly from the life in the 1500s, see the Snopes.com article via the following link:

<http://www.snopes.com/language/phrases/1500.asp>

Snopes.com is a good source for you to use for those rumors and urban legends you receive routinely by email. Check rumors out via Snopes.com before passing them on.



REFERENCE MATERIAL AVAILABLE FOR PURCHASE

Old STGS Newsletters

From its inception in 1987, up to and including 2006, there have been over 80 STGS Newsletters published. Many of the older newsletters (pre 1996) contain genealogical material (over 300 pages) extracted from various 19th century St. Tammany Parish resources, including but not limited to: St. Tammany Parish Marriage Records (1811-1861), Successions (Book #1), CSA Families, Register of Donations (Book A), Citizenship Application abstracts, Mortgage Books (Books A & B), Conveyances (Book A), plus unrecorded records from the court house files.

All of the previous issues of the STGS Newsletters are now available for purchase! An entire set of pre 2001 (66 newsletters in all) can be purchased for \$75 (\$65 for members). This newsletter collection is now contained in a 3-ring binder with tabs for each year. Individual newsletters from this set are not available for purchase. Postage & handling is \$7.00, if shipment of the newsletters is required. Send questions or purchase requests to:

St. Tammany Genealogical Society (STGS)
c/o Robert B. Noles
133 Acadian Lane
Mandeville, LA 70471
Phone: 985-845-4688
Email: rbnoles@bellsouth.net

“Those Who’ve Gone Ahead”

Published by the St. Tammany Genealogical Society, this book contains the extractions from the records of the E. J. Fielding Funeral Home, Inc., in Covington, Louisiana. These extracts, which are fully indexed, contain the genealogical data from the Funeral Home’s records containing the information supplied to them by the family, friends, or agents of the deceased. The book covers 1992-1998.

The “Those Who’ve Gone Ahead” book, which was primarily the work of Patricia Gros is available in soft cover only for \$19.95 for STGS members and \$24.95 for non members. Postage & handling is \$5.00, if shipment of the book is required. Send questions or purchase requests to:

St. Tammany Genealogical Society (STGS)
c/o (Mrs.) Martha Dutsch, STGS President
P.O. Box 1155
Covington, LA 70434
Phone: 985-892-6561
Email: dutschm@netzero.net



**Louisiana STGS Lapel
Pins \$6.00**

**Contact
Martha Dutsch
to purchase a pin**



THE CENSUS TAKER'S HOME

by Jan Philpot

Ever wonder why those censuses just don't add up sometimes? Well we all have "our days" when our world is topsy turvy and affects most everything that happens, and I figure a census taker did too. Of course he might not have realized just how far reaching the effects of his bad day might be...

Well, I'm surely glad to be home, that I am. I tell you another day like this one and I am good mind just to fill them papers out on memory and be done with it. Here, put these socks over there next to the fire to dry out, will you? Got down yonder this mornin and everyone in Household 451 through 486 was gone. Some big shindig going on down there. Good thing the folks in 441 could tell me who they all was. Here, reckon you could go over some of the writin on this here page? Got smeared a bit in the rain. I think you can cipher most of it out.

Then them folks down in the holler got suspicious over a census. Said, and derved if they had a point, what difference did it make who they was? Was them guvment folks up in Warshington going to come down here to say howdy do? So they finally let me write down they last name and first initial, but I think they wuz havin a bit of fun with me when they listed who lived in the house. Saw some winkin goin on and I believe I got the same house a youngins in two or three places. It been a day, woman. Honey, git that paper out of Johnny's mouth, will ya? I worked all day on that thing, and no call to let him go chewin it up.

Went up the river a piece and tried to get that done fore it come a downpour, but run into trouble there too. Ole Man Jenkins curr dog run me off and I tell you, ain't no call to get eat up over such a thing as this. They ort to be a limit what a man does for his country. Was lucky man down the road mostly knew Jenkins was nigh on sixty years old and was living there with his woman and five youngins from his

first marriage plus a passel from the second. We give em good Christian names. Best be doin something bout this pen. It give out on me halfway through. See you havin trouble too. Johnny! Hand that here, boy!

And I tell you I would ruther fight grandpap's British than mess with that feller out on the ridge. He got out his shotgun soon as he seen me comin and I went



t'other direction. Had Jones tell me about him instead, and he didn't rightly know the feller's first name. said

they called him "Squirrel", and it was ok just to put that cause wasn't nobody around here claimin him no how, and they for sure didn't want the guvment knowin there was any relationship. That coffee done?

Then got over to Smiths, and ole Hoss was in a nervous fit so wasn't no getting information there. His woman havin another youngin and he looked like he could run right through me when I went to askin how many youngins he had now. Hightailed it out of there, and Miz Hart helped me straighten that household out. Think we got most of the names straight, and as he has had a youngin a year for the last ten, ages purty close too. Now look what Johnny went and done!

I tell you, next time this come around I ain't gonna be no where in sight. Farmin a heap easier, and I figger there folks round here what can read and write and cipher and ain't no good fer nothing else we can spare for this foolishness. Pass me another tater, will you?



DNA TESTING FOR AMERICAN INDIAN ANCESTRY

By R. B. Noles

I manage a number of DNA projects for genealogical research (about 20 in all), including many individual surname projects, plus the Wiregrass Georgia Regional DNA Project (southeastern Georgia), the West Florida Parishes Regional DNA Project (southeastern Louisiana) the Lumbee Tribe Regional DNA Project (for those people who have Lumbee ancestors or who think they might have Lumbee ancestors) and recently I joined the team of project administrators for the Lost Colony of Roanoke Island Project (from 1587).



The Lumbee Tribe is the largest (by far) Indian Tribe East of the Mississippi River. The Lost Colony Project is attempting to identify the descendants of the Roanoke Colony, assuming some of them survived. (watch for a Lost Colony article in a future issue of the STAR).

I have been very involved with DNA testing in support of genealogy since its inception in 2000. I have truly seen fantastic discoveries in terms of genealogical and family history findings using DNA as a tool. Do you have family stories indicating a Native American heritage of possibly a connection to a member of the Lost Colony? If so, you should investigate obtaining a genetic genealogy test

My wife's (Dyann) paternal line ancestry (surname = Hersey or Hursey) was established as being American Indian (or Native American if you prefer) using a Y-DNA test for her uncle. All previous Native American research for the Hersey line was based on old family stories that indicated the family's Native American ancestor was a female and of Cherokee descent. As a result of the DNA test results, our genealogical research efforts are aimed at determining who specifically was the Native American male an-

cestor and establishing where he lived before migrating to the Wiregrass Georgia area in the very early 1800s. Hence the reason for establishing the Lumbee Tribe DNA Project. Migration into southeast Georgia starting in the late 18th century was extensive from the North and South Carolina region (Robeson County, NC and vicinity) where the Lumbee Tribe was prominent.



Many American families have oral histories of Native American heritage. In many cases, the family stories are for the most part true. Proving the oral tradition is another matter, unless you are lucky enough to have documentation passed down from your Indian ancestor. We normally think of either the Western tribes that still reside in or near their indigenous homes, or the Cherokee who were largely displaced from their homeland in the 1830s.

The history of Native American heritage in North America is much more complex. Most people who have a family oral history of 'Cherokee heritage' are more likely to be a descendant of a tribe other than Cherokee. The Cherokee were not the only tribe in the Eastern U.S. The Eastern seaboard was widely populated by varying tribes, some of which were related or affiliated. There were three major language groupings; Algonquin, Souian and Iroquoian scattered throughout the Eastern seaboard northward to Canada, westward to Appalachia and south to the Gulf of Mexico.

In the early years of white settlement in the new world, European women were scarce. Few women traveled to America in the early years of the Colonies. Many of the early European settlers traded with, worked alongside with and married into the indigenous families.

See American Indian (Continued on page 32)



FAMILY TREE MAKER 2008

Press Release by Ancestry.com

Revamped Software Continues 18-Year Legacy of Innovation and Excellence; Offers Users Online Integration with Ancestry.com and Other Web Resources Including Microsoft® Virtual Earth™

PROVO, Utah, Aug. 14 -- Ancestry.com, the world's largest online resource for family history, today announced the release of Family Tree Maker 2008, a completely redesigned and ground-breaking version of the world's No. 1 selling family history software. Family Tree Maker 2008 boasts an intuitive new interface and dozens of new features built on an entirely revamped, modern platform - the result of a two-year, back-to-the-drawing-board development process.



In one software bundle, Family Tree Maker 2008 provides users tools to quickly build their family trees, record their memories and organize their family photos, stories, video and audio clips. Users can quickly find and import facts and historical documents about their family from the Internet and print custom-designed family trees and books. With dynamic satellite maps and customizable timelines, Family Tree Maker 2008 truly broadens the capabilities that every family history program should include.

"Family Tree Maker 2008 redefines family tree building software, providing users with powerful, unrivaled tools and resources to discover and share their family stories," said Tim Sullivan, CEO of The Generations Network, Inc., parent company of Ancestry.com. "The software's seamless integration with the Ancestry.com Web site further solidifies Ancestry.com as the family history authority both on and offline."

Family Tree Maker users can tap into Ancestry.com's unrivaled collection of family history records and powerful search features - without leaving Family Tree Maker. When connected to the Internet, Family Tree Maker 2008 automatically searches Ancestry.com for historical documents about the individuals in the user's family tree. With a few mouse clicks, users with an Ancestry.com subscription can view and import these historical records into their family tree.

"Family Tree Maker 2008 offers every user an intuitive out-of-the-box experience," said Megan Smolenyak, Chief Family Historian for Ancestry.com. "Ancestry.com developers worked closely with industry professionals as well as family history beginners to create a program that uniquely spans the range of user ability with an easy-to-use interface that also offers advanced, robust features."

The following new and updated features expand Family Tree Maker's capabilities:

- Interactive Street and Satellite Maps - Use Microsoft® Virtual Earth™* to access dynamic street and satellite maps that pinpoint important locations in ancestors' lives from within Family Tree Maker. A place-name database and hint engine helps users correctly enter localities in a consistent format.

- Web Integration -View and search any Web site from within Family Tree Maker*. Once users locate information about their ancestors, they can easily import appropriate images, text and even a cached version of the Web page in to their family tree.

See FTM 2008 (Continued on page 23)



FTM 2008(Continued from page 22)

-- Individual Biographies - Create biographical sketches for each ancestor, adding life facts, historical documents, photos and other digital media. In addition, timelines highlight important personal, family and world events that occurred during ancestors' lifetimes.

-- Media Organization -Upload and manage image, audio, video and other media files. Users can attach these files directly to specific people in a family tree to better illustrate their family story.

-- Publish Family History Books - Create customized, illustrated family history books. Ancestry Press allows users to bring their family history to life with professionally designed charts, timelines, reports and pedigree charts, as well as photos, historical records and more. The books can then be professionally printed and bound (or printed on home printers).

First released in 1989, Family Tree Maker ranks in longevity among Microsoft Windows (first released in 1985) and Adobe Photoshop.

Family Tree Maker 2008 is now available for sale online for \$39.95 at:

<http://www.familytreemaker.com/>

FTM 2008 is also set to be released in select retail stores in October 2007.

* Internet access required for Microsoft Virtual Earth and other Web integration.

About Ancestry.com

With 24,000 searchable databases and titles,

Ancestry.com is the No. 1 online source for family history information. Since its launch in 1997, Ancestry.com has been the premier resource for family history, simplifying genealogical research for millions of people by providing them with many easy- to-use tools and resources to build their own unique family trees. The site is home to the only complete online U.S. Federal Census collection, 1790-1930, as well as the world's largest online collection of U.S. ship passenger list records featuring more than 100 million names, 1820-1960. Ancestry.com is part of The Generations Network, Inc., a leading network of family-focused interactive properties, including MyFamily.com, RootsWeb.com, Genealogy.com and Family Tree Maker. In total, The Generations Network properties receive 10.4 million unique visitors worldwide and over 450 million page views a month (© comScore Media Metrix, March 2007).

FTM 2008 Note from the Editor

R. B. Noles was a Beta Tester with Ancestry.com for FTM 2008. As a Beta tester, I was able to see the development process first hand (at the beginning of testing last Spring, FTM 2008 had not reached Beta testing status).

Please be aware that this version of FTM bears no resemblance to prior versions. The new version is not an upgrade with a few new features, but a completely new program.

I cannot even open my main FTM file with FTM 2008. FTM 2008 is seriously lacking in important features that have been available in past versions for years. Files that do load may be missing some facts.

I do NOT recommend the purchase of FTM 2008 at this time.



STGS Meeting Schedule



- Tuesday, November 13, 2007 - Board & Volunteer Meeting
- Tuesday, December 11, 2007 - Christmas Luncheon at Benedicts
- Saturday, January 12, 2008 - Regular Business Meeting + Speaker (TBD) *
- Saturday, February 9, 2008 - Regular Business Meeting + Speaker (TBD) *

NOTE: Regular Meetings are held in the Covington Branch Library, Meeting Room at 1:30PM, except as noted.

* The presentation at one of these meetings will be on "Looking for The Descendants of the Lost Colonists from Roanoke Island"

Robert B. Noles
Genealogy Research

133 Acadian Lane
Mandeville, LA 70471
985-845-4688 (Voice & Data)
985-845-4698 (FAX)
rbnoles@bellsouth.net (Email)

Contact Rob Noles concerning your genealogy tutoring needs.
One Hour FREE for STGS Members.

At American Bank & Trust Co., we still attend to our customer's needs the old fashion way....
INDIVIDUALLY

American Bank & Trust Co.

Hours
Lobby— 9 am to 4 pm
Friday— 9 am to 5:30 pm
Saturday— 9 am to 12 noon
Drive Thru— 9 am to 4 pm
Friday— 9 am to 5:30 pm
Saturday— 9 am to 12 noon

Covington Branch: 1819 N. Columbia St. (across from the Post Office) 898-0206
Mandeville Branch: 406 N. Causeway Blvd. 826-7737

SILVER EAGLE ENTERPRISE
"FLAGS & FLAG POLES"

Martha Dutsch

P.O. Box 1155
Covington, Louisiana

Phone: (985) 892-6561
Cell Phone: (985) 705-4332

Put your business card here!
(ask the STGS for rates for larger ads)

1 time \$25
2 times \$45
3 times \$65
4 times \$80



FGS & NGS

The STGS is a member of both the National Genealogical Society (NGS) and the Federation of Genealogy Societies (FGS). Both of these organizations sponsor major genealogical conferences, offer genealogical research instructions, provide informative newsletters, and, in the case of the NGS, maintain a major genealogical lending library. Because the STGS is a member of these national genealogical organizations, you, as members of the STGS, can take advantage of many of the services of these organizations for free or at reduced prices. Do yourself a favor and investigate what these two organizations can do for your research efforts.

STGS MISSION & GOALS

The mission and the goals for the STGS are to encourage the study of genealogy; to foster and support the development and maintenance of family trees for the ancestors that lived in the Florida Parishes; to create interest in the genealogical records found in and around St. Tammany Parish, Louisiana: to locate and make known the locations where genealogical records are available; to preserve, catalogue and publish when possible the records of a genealogical nature where such records may be of interest to members, subscribers and students of genealogy; to support genealogical researchers who had ancestors from the St. Tammany Parish area; to provide training in the field of genealogy; and to bring to the attention of the public in general the necessity of preserving records of a genealogical nature for the benefit of posterity.

The STGS shall foster this mission and these goals by holding regular meetings, conducting field trips to regional genealogical facilities, providing genealogical training workshops, publishing a quarterly newsletter and by maintaining an informational web site.

STGS DUES SCHEDULE

New membership categories and the corresponding schedule for dues for the STGS took effect on January 1, 2002, for calendar year 2002. Membership categories and dues are:

- ◆ Individual Adult Membership - \$15.00
- ◆ Family Membership - \$22.50 *
- ◆ Student Membership - \$5.00 **
- ◆ Genealogical Society - Newsletter exchange ***
- ◆ Library Membership - \$45.00 ***
- ◆ Business Membership - \$60.00 ***
- ◆ Individual Honorary Membership - No dues
- ◆ Individual Life Membership - Per schedule

* Family Memberships shall have only one vote

** Full time students under the age of 25 are eligible to become Student Members

*** Non-voting memberships

Life Membership Dues Schedule

Under 40	- \$250
40 to 49	- \$200
50 to 54	- \$150
55 to 59	- \$125
60 to 64	- \$100
65 to 69	- \$75
70 to 74	- \$50
75 to 79	- \$25
80+	- Free

The Life Membership Dues Schedule is based on the age of the member before 12/31 of the year preceding the membership year.



The new Bylaws for the STGS became effective on May 8, 2001. The new dues schedule above was approved by the membership at the October 2007 regular meeting.



GENEALOGY BOOKS FOR KIDS

Book Review By Dick Eastman

The following article is reprinted from the June 27, 2007, issue of "Eastman's Online Genealogy Newsletter."

Roots for Kids: A Genealogy Guide for Young People. 2nd Edition (Book Review)

We generally think that an interest in genealogy starts in middle age or perhaps later. Yet those of us who have spent a lot of time in genealogy libraries and in courthouses almost always can tell you of exceptions. One of the leading professional genealogists I know is now in his late twenties but got started before he was old enough to obtain a driver's license. His mother used to drive him to the libraries and courthouses. He reports that he was interested at an even earlier age but delayed until his early teens simply because he didn't know how to get started when he was younger.



Professional genealogist David Lambert is very proud of another genealogist in his family: his eleven-year-old daughter, Brenda, is an accomplished researcher, capable of doing high-quality research, even when her father isn't around.

I have also given several genealogy presentations to third graders and have been amazed at their enthusiastic responses. I always hand out blank pedigree charts at these classroom sessions and explain the use of the charts. One teacher later told me that several students came back to school the next day with filled-in pedigree charts, even though that was not an assignment.

I was a "late bloomer." I conducted my first genealogy research project at the age of fifteen as an English class writing assignment. I was hooked then, although school, military service, and starting a family delayed my family tree research for several more years.

There are many more such examples. Perhaps you had an early interest, even if you delayed that interest until later in life.

Is an interest in one's ancestry really a personal interest that doesn't develop until mid-life? Or have we simply not provided the proper introduction to youngsters? One new book seeks to find out by providing that introduction.

ROOTS FOR KIDS: A Genealogy Guide for Young People, by Susan Provost Beller, seeks to provide the genealogy introduction and foundation for school children. The book is designed as a project in which a child and adult work together. The adult does not need to be a genealogy expert; both can learn at the same time.

The book is designed as a twelve-week lesson plan with one "class" per week. It should work well either in a classroom environment with multiple students or at home in a one-on-one setting. The book seems to be aimed at fourth through sixth grades (ages 9 through 11) in a teacher/student environment. It could also work well with older students as a self-taught genealogy course with minimal teacher involvement, if any. If this book can become available in every junior high school library, I suspect the number of young genealogists will multiply every year!

As in most genealogy "how-to" books, *ROOTS FOR KIDS* starts off with an introduction to genealogy. It especially like the idea that the introduction stresses the fact that a family tree is a collection of stories, not a simple collection of names, dates, and places. Quoting from Chapter One: An Introduction to Genealogy:

"Each person on your family tree is a story waiting to
See Kids (Continued on page 27)



Kids (Continued from page 26)

be told. No matter what a person did in his life, he has a story to tell. This book will help you to discover how to find those stories. Some of the stories will be dull, but most of them are really interesting. You may be surprised to find all the great things your ancestors did in their lifetimes. Some of the stories are also a lot of fun.

"One example is a story of a relative of my husband. This man has been dead for over ninety years but one of his stories is remembered to this day. As a kid, he was famous for his Halloween pranks. One Halloween he and some friends managed to coax the neighbor's cow up onto the roof of a barn. It took the townspeople most of the next day to get the poor cow back down!"

I suspect every mischievous nine-year-old can identify with that story. In fact, this "older child" also finds it amusing!

The remainder of *ROOTS FOR KIDS* builds upon similar material; it frequently stresses why the reader will find the family tree to be so interesting.

ROOTS FOR KIDS then leads the student (and teacher) through discussions of relationships (what is a second cousin?), how to ask questions, how to organize research materials, and how to use the Internet to conduct research in local, state, and national records. Susan Provost Beller weaves her own stories in and out of this book in order to give examples of what the student may find in his/her own family tree.

The current *ROOTS FOR KIDS* is the Second Edition. I never saw the First Edition, but the new book's advertising states that a lot of new material has been added about using the many online resources of libraries and historical societies without leaving home.

Susan Beller is well qualified to write this book, and her experience shows. She has been involved in genealogical research for more than three decades. In addition to her teaching experience with young peo-

ple, she has taught advanced genealogy courses to adult education classes.

ROOTS FOR KIDS is an excellent resource for teaching children about their own history. Along the way, they gain meaningful experience in research methods, history, geography, language, communication, analysis, and culture, to name a few disciplines. Its format as step-by-step lesson plans makes for a logical sequence through what can be a fascinating lifelong study for youngsters and old-timers alike. This book should work well in either a classroom setting or one-on-one. If you have an opportunity to teach youngsters, I strongly suggest that you should obtain this book and study it closely.

ROOTS FOR KIDS, by Susan Provost Beller, is published by Genealogical Publishing Company and should be available through any bookstore if you specify ISBN: 9780806317779. In addition, you can purchase it for \$19.95 plus taxes and shipping from the publisher's safe and secure online ordering system at:

http://www.genealogical.com/index.php?main_page=product_info&item_number=422&NLC-GenPointers1





Viva La Louisiane!!!

Just in case Hurricane Katrina causing the levees to break in New Orleans is the only thing you know about Louisiana, here are a few more interesting facts about the Bayou State:

Louisiana has the tallest state capitol building in the nation at 450 feet.

The Louisiana Superdome in New Orleans is the largest enclosed stadium in the world.

The Lake Pontchartrain Causeway is the longest over-water bridge in the world at 23.87 miles.

Louisiana's 6.5 million acres of wetlands are the greatest wetland area in America.

The oldest city in the Louisiana Purchase Territory is Natchitoches, Louisiana founded in 1714.

The first bottler of Coca-Cola, Joseph Biedenharn, lived in Monroe, Louisiana.

Delta Airlines got its start in Monroe, Louisiana. (But before it was named Delta, it was Chicago & Southern.)

Southern University in Baton Rouge, Louisiana is the largest predominantly black university in America.

Baton Rouge was the site of the only American Revolution battle outside the original 13 colonies.

The formal transfer of the Louisiana Purchase was made at the Cabildo building in New Orleans on December 20, 1803.

The staircase at Christien Point, in Sunset, Louisiana was copied for Tara in "Gone with the Wind."

Louisiana is the No. 1 producer of crawfish, alligators and shallots in America.

Louisiana produces 24 percent of the nation's salt, the most in America.

Much of the world's food, coffee and oil pass through the Port of New Orleans.

Tabasco, a Louisiana product, holds the second oldest food trademark in the U.S. Patent Office.

Steen's Syrup Mill is the world's largest syrup plant producing sugar cane syrup.

America's oldest rice mill is in New Iberia, Louisiana at KONRIKO Co.

The International Joke Telling Contest is held annually in Opelousas, Louisiana.

LSU "The Ole War Skule" in Baton Rouge has the distinction of contributing the most officers to WW II after the U.S. military academies.

The Louisiana Hayride radio show helped Hank Williams, Elvis Presley and Johnny Cash achieve stardom. It was broadcast from KWKH Radio in Shreveport, Louisiana from 1948 to 1960.

The term Uncle Sam was coined on the wharfs of New Orleans before Louisiana was a U.S. territory as goods labeled U.S. were from "Uncle Sam."

The game of craps was invented in New Orleans in 1813 as betting was common activity on the wharves.

When states had their own currency, the Louisiana Dix (French for ten) was a favored currency for trade. English speakers called them Dixies and coined the term Dixieland.

New Orleans is the home of the oldest pharmacy in America at 514 Chartres Street in the French Quarter. These early medical mixtures became known as cocktails (guess they were good for what ails ya?) coining yet another term.

New Orleans is the birthplace of Jazz the only true American art form. Jazz gave birth to the Blues and Rock and Roll music.

Viva La Louisiane!!!



LOST COLONY SYMPOSIUM

By R. B. Noles

My wife, Dyann (Hersey) Noles and I just returned home from North Carolina and the Lost Colony Symposium.

Some of you may be familiar with the fact that many of the southeastern U.S. pioneers were descendants of Native Americans (or American Indians, which is the preferred term among many present day tribe members). Accordingly, I established the Lumbee Tribe DNA Project a couple of years ago, because Dyann's male HERSEY line tested to be American Indian. This was a surprise, because the Hersey family stories indicated the Hersey American Indian ancestry was a female. The Lumbee Tribe from Robeson Co., North Carolina (the largest Indian Tribe east of the Mississippi River) is the most likely source for most American Indian genealogical connections.

The Lumbee Tribe is the 20th century name for the tribe which is a melting pot of various small Indian tribes from eastern North Carolina from the 16th, 17th and 18th centuries, as well as Europeans and Africans who were in the Robeson Co., North Carolina region in the 18th century. Many intermarriages occurred among the various original small tribes and the white and black inhabitants in the area.

A theory (based on credible circumstantial evidence) has existed for many years, that the survivors (if any) of the Lost Colony of Roanoke Island (founded in 1587 by Sir Walter Raleigh) integrated and were absorbed by one or more of the eastern North Carolina Indian tribes. In the 1730s, when the Scots, who were exploring and looking for land on which to settle in what is today the Robeson County area, discovered the Indians living in the vicinity. These natives were obviously Indian, but had no real Indian traditions, they spoke English and farmed using methods previously used in England hundreds of years previous. These Indians were the ancestors of the present day Lumbee Tribe.

No credible theories exist as to why this isolated group of Indians in the 1730s would have such obvious England backgrounds other than that their ancestors were from the Lost Colony and perhaps other English and African sailors who ship wrecked or who were abandoned along the coast of North Carolina in the 16th and 17th centuries.



So, in addition to my Wiregrass Georgia and Lumbee Tribe genetic genealogy projects, I became interested in the new Lost Colony DNA Project initiated by Roberta J. Estes. Roberta held a Symposium concerning the Lost Colony in September in Williamston, North Carolina. Many locals were DNA tested at the Symposium, giving the Lost Colony DNA Project a jump start. As a result of my attendance at the Symposium, I have added the Lost Colony DNA Project to my efforts and as a possible source for some of the ancestors of the West Florida Parish's pioneers. Stay tuned, a more complete Lost Colony article will appear in the next issue of the STAR.

Those of you who are interested in using genetic testing in advancing your genealogical research or just learning more about your deep ancestry, should join the West Florida Parishes DNA Project. An application can be found via the following link:

https://www.familytreedna.com/surname_join.aspx?code=r53617&special=true

LOST COLONY PROJECT MISSION

To gather as much data as possible to prove that at least some of the colonists did in fact survive as has been suggested by numerous historical accounts, possibly having assimilated into the indigenous tribes of the area or having been taken captive, or both. As the various tribes moved inland, the colonists would have moved with them. If the colonists were enslaved, they could have been sold or traded

See Lost Colony (Continued on page 31)



Bernard de Marigny and Early Mandeville

SHIFT MARRIAGE

From Encyclopedia of Genealogy

The St. Tammany Historical Society and the St. Tammany Genealogical Society co-sponsored “Bernard de Marigny and Early Mandeville” on September 15, 2007 in Lacombe. Attendees experienced Chef John Bech’s culinary delights at the refurbished La Provence Restaurant. Two presentations were made:



SPEAKING OF HISTORY: St. Tammany Historical Society featured speakers David Carambat of Covington and Sally Reeves of New Orleans.

Mr. David Carambat, Maritime Historian and exhibit designer presented an overview of environmental history of the Mandeville area, the transportation history, and the development of Mandeville as a resort community.

Ms. Sally Reeves, retired Notarial Archivist of Orleans Parish, a nationally recognized archivist and conservator discussed Bernard de Marigny, the Marigny family and the early evolution of his town; Mandeville.

Mr. Carambat and Ms. Reeves have spent months researching the Mandeville area in preparation for a new exhibit entitled “Mandeville: The Good Life.” This exhibit is slated for an early 2008 opening at the Mandeville Trailhead. Watch for it!

The “Bernard de Marigny and Early Mandeville” event was well attended and sold out weeks ahead of time. Many potential attendees failed to make reservations early enough to obtain a reservation and were disappointed. The large attendance surprised Robin Leckbee, the President of the Historical Society and the organizer for this event.

Perhaps other jointly sponsored events will be sched-

The term “Shift Marriage” refers to a pre-marriage ceremony between a man and a widow; not all such marriages, apparently, but only when the widow had received substantial property from her deceased husband. The custom was that she would appear before witnesses dressed only in her shift (nightgown). The husband would then affirm before the witnesses that he accepted her as she was—in other words, only herself, not the property she had received from her first husband—and renounced any claim to her property, and also made it known that he would not pay off any debts that the widow inherited.

An example, from the Vital Records of Barnstable, Massachusetts:

Nathan Noyes & Mehitable Bangs wid: Sept 20 1750 ye Bride Setting in ye Bed ye Bridegroom Declared before ye witnesses present that he took her in her Shift as She was, having never Received anything of her former Husbands Estate nor expecting to Receive Any and that he would not pay any of ye debts of it - This Returned on ye Back of ye Certificate Pr Mr Green Attest David Crocker Town Clerk.

uled in the future.

The pictures with this article are courtesy of the Times Picayune.

Many pictures from this event appeared in the Sunday, October 14, 2007 edition of the Picayune in the Living Section.

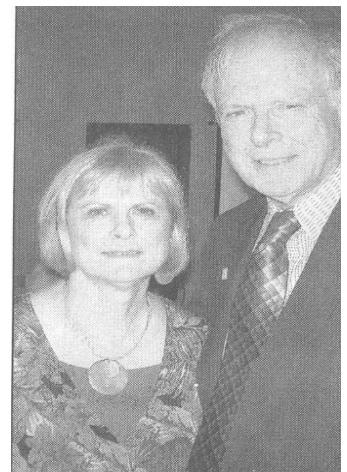

Dyann Noles and St. Tammany Genealogical Society First Vice President Robert Noles of Mandeville. The genealogy society co-hosted the event.



ST. TAMMANY PARISH HISTORY

By St. Tammany West Chamber of Commerce

In a state that has known ten flags, every town can make some claim to historical significance. St. Tammany's early history was characterized by the domination of European powers. More often than not, New Orleans lay under one flag while the Northshore labored under another. That arrangement may have contributed to the earliest settlement at the mouth of the Tchefuncte River. A trading community in that location would have offered real convenience to merchants seeking to bring goods into New Orleans without the security of colonial officers.

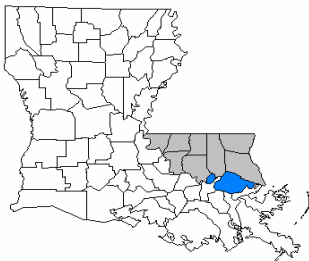

Louisiana West Florida Parishes

Although it was eventually incorporated in the state of Louisiana, St. Tammany was not included in the Louisiana Purchase in 1803. It existed instead as part of the western panhandle of Florida until 1810. At that time, a well-organized group of American insurgents led a violent rebellion

against the ruling Spanish authorities, seizing the Spanish fort at Baton Rouge and declaring West Florida an independent republic. In the five months before being assimilated into the United States, this small band forged their own declaration of independence, constitution, bill of rights, and even a national anthem.

St. Tammany Parish was named for a Delaware Indian Chief named Tammenend for reasons that still remain unclear. The original parish courthouse, built in 1818, is the last remaining structure of what was once the town of Claiborne. It still stands across the Bogue Falaya River from Covington, which became the parish seat in 1829.

The Northshore has been a refuge for wealthy New Orleanians since almost the very beginning as they sought to escape yellow fever, Yankees and the stress of urban life. Abita Springs, in particular, was

widely recognized for its healing spring water and resort hotels. At one time, a trolley car ran all the way from the Mandeville lakefront to those Abita resorts.

During both World Wars, Madisonville served as a significant shipbuilding center.

When the single span 24-mile Lake Pontchartrain Causeway opened in 1956, development came to the western parish in earnest. The second span opened to the public on May 10, 1969. Today over 40,000 cars cross the causeway daily.

Lost Colony (Continued from page 29)

and not remained as a group, being scattered to various locations.

Our research group will be working to connect the genealogies with the historical records and genetic results from individuals who are likely candidates to be descendants of the Lost Colonists. We have assembled names of interest that are compiled from the Lost Colony settlers and also from the early families found in the areas where the colonists are believed to have settled. Early land transactions and grants reference individuals with many of these last names as Indians. Possible candidates to be connected to the Lost Colony come from the following groups of individuals:

1. Those who have any of the surnames of interest and whose genealogy ends abruptly early in Eastern Virginia or North Carolina.
2. Those who connect via any of these surnames to the British Isles.
3. Those whose family has an oral history of being connected to the Lost Colony.
4. Those with Native American heritage from Eastern or early Virginia or North Carolina.

<http://www.rootsweb.com/~molcgdrg/>



American Indian (Continued from page 21)

A basic question that I receive quite often is: "IF MY ANCESTRY is Native American, will I be able to prove it with a DNA test?" Typically there is some level of misunderstanding (or perhaps a basic lack of knowledge) about what the different types of DNA testing can tell you about your Native American ancestry and how. I don't work for nor do I receive any type of compensation from any lab or company involved with genetic testing. However, I do interpret test results for people who join one of my DNA projects, so I don't want people to obtain a genetic genealogy test without understanding what can and cannot be learned from any given test.

For that reason, I'd like to take just a minute of your time and provide you with a quick summary of what can and cannot be determined from DNA testing for American Indian ancestry and why. The following is a description of the four different types of genetic genealogy tests and what they can tell you about your native ancestry.

1. Mitochondrial DNA Testing (mtDNA):



This test is only good for your direct maternal line (your mother, your mother's mother, etc.), because mitochondrial DNA is passed down from a mother to her children intact without any influence from the father's mtDNA. In other words, only females pass mtDNA on from generation to generation. If your direct maternal ancestor was of American

Indian origin, your mtDNA test results will likely show specific Haplogroups, or clans, A, B, C, D or X (the Haplogroups found in Native Americans). If your direct maternal line is not Native American, it doesn't mean that the rest of your lines aren't. However, the mtDNA test does provide you with a positive result for this specific line in your ancestry. If you want to test other lines in your ancestry using the mtDNA test, then you need to recruit relatives and/or other descendants through the appropriate maternal

lines for additional tests. This has been done successfully by some genealogists and has proven or disproved their native ancestry link on that line.

The following three generation chart shows the inheritance pattern for mtDNA.

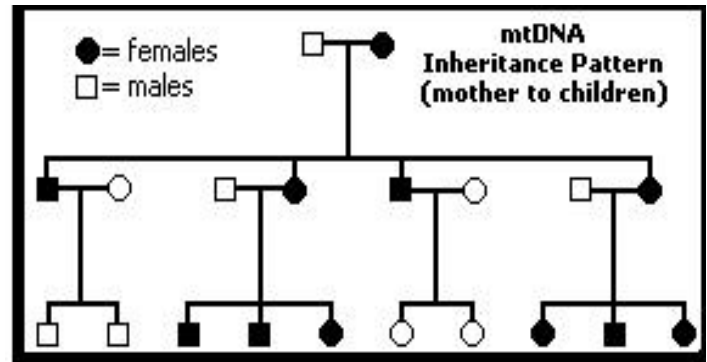

2. Y-DNA Testing:

This test is for the direct paternal line that normally follows a surname; i.e., your father, your father's father, etc. The Y-chromosome is passed down intact from father to son, generation after generation without any influence from the mother, as she does not have a Y-chromosome.



Therefore, the Y-DNA test can tell you for your direct male line whether or not it is of Native American ancestry.

A Y-DNA test result identifying your Haplogroup as Q3 (and sometimes C) would indicate descent from an American Indian man. However, we also see lots of men who are 'card-carrying' Native Americans, with Y-DNA test results reflecting Haplogroup R1b (an Indo-European Haplogroup). Why, you ask? Because of the centuries of exposure and intermarriage of American Indians with the descendants of Indo-Europeans. So, a test result that's not indicative of an American Indian Haplogroup doesn't mean you are not of Native American ancestry, (whatever that means to you).

See American Indian (Continued on page 33)



American Indian (Continued from page 32)



What it does mean is that your Haplogroup (and your direct male line ancestry) is not from an indigenous Native American. Conversely, some people take the Y-DNA test not expecting to be of native heritage and discover that they are (as was the case for my wife's uncle). In fact, 95% of the participants in the Lumbee Tribe DNA Project (those tested so far) do not have a Native American Haplogroup result from their Y-DNA test.

The following three generation chart shows the inheritance pattern for Y-DNA.

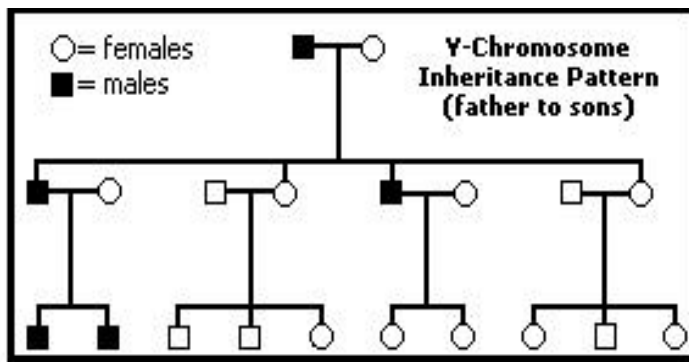

3. DNAPrint Genomics Testing: This specific autosomal test (meaning using markers from all of your chromosomes) is patented and while it is resold by other firms, there is only one of these tests available. The DNAPrint tests a small portion of all of your genes, not just the Y-chromosome or the mtDNA discussed above, that are passed intact from only one parent. The DNAPrint test uses a sampling of all of the genetic data that is passed to the child from both parents. The DNAPrint test looks for specific markers that the company has not identified to the general public. This is a proprietary test. They have found specific markers in some percentage of the populations they look for; therefore, they combine the percentages of likelihood into a final statistical number for you telling you how much percent-

age-wise you are of each of the major type of ancestry; i.e., Indo-European, Native American, East Asian and Sub-Saharan African.

For example, if a particular marker is found in half of all the Native Americans they have tested, and another marker is found to be in 95% of Native Americans, and you only have the 50% marker, then somewhere in your past there is a 50% chance you have a Native American ancestor. Actually, it gets even more complex, because let's say this particular marker is also found in 10% of Indo-Europeans. Now, if you carry that marker, is it Native American or European?

That's why the DNAPrint test looks at over 500 markers to come up with your predication. Notice, for the DNAPrint test, I said prediction...that is exactly what it is...a statistical prediction of how much Native American ancestry (or Indo-European, or Sub-Saharan African, or East Asian) you carry. To make this even more tenuous, the DNAPrint company says in their literature that somewhere between 9-15% is their margin of error, meaning that if your test results show 12% Native American, are you 12% Native American or 0% Native American or somewhere in the middle.



With low admixture percentage amounts from a given racial group, you don't know for sure if what you're seeing is noise or something meaningful. While this testing method and the DNAPrint test is imperfect, this is the only way to even begin to determine a percentage of Native American ancestry for you as a whole. The DNAPrint test isn't like an mtDNA or Y-DNA test that will tell you specifically that the line represented is Native American or not.

See American Indian (Continued on page 34)



American Indian (Continued from page 33)



4. Paternity Testing:

The last kind of DNA testing of potential interest to genealogists is the kind of test done for paternity testing. It's called forensic or CODIS testing and it too uses your autosomal DNA contributed by both of your parents. This kind of testing tests only certain markers or locations well

known and understood by everyone, unlike the proprietary testing used for the DNAPrint test. This is the testing performed to establish paternity, siblingship, etc. for medical or legal reasons. While the Y-DNA testing can tell you if you descend from a common male ancestor, it cannot identify your father (although it can clearly disprove that a particular man is your father). This testing uses 15 markers typically used in police work and was designed to identify a person individually and uniquely. The Y-DNA and mtDNA tests do NOT produce results that are unique to you as an individual; therefore, they are of no use for any purpose other than genealogy. You carry two versions for each of the CODIS 15 markers; one from each parent. So, if you know what the DNA is for both parents, you can eliminate the mother's DNA easily from the matches and that leaves the DNA of the father. If the marker values you carry that's left doesn't match that of your father; he isn't your father.

When the parent is deceased or unavailable, you can sometimes use other close relatives as a substitute. You can also do siblingship testing this way as well. There are several variables in how much this type of test can tell.

For example, in one case a researcher found a person she believed was a long-lost half brother by her father and they wanted to know if they were really half-siblings. Their father was dead and so was the mother of the half-brother. The researcher's mother

was living so they subtracted her DNA from her mother's DNA and compared what was left. What they received back was a "probability index" that said they were some percentage likely or unlikely to be half-siblings. Had the suspected half-brother's mother been living or if he had any siblings from his mother, they could have narrowed the probability down a bit.

Back to Genealogy: Since the specific markers used for the paternity or forensic DNA tests are public information, people have compiled databases of the results that includes primary ethnicity. In the genealogy field, researchers have been comparing their autosomal results to these forensic databases to see if they match someone from a specific ethnic group. There are huge issues with this, not the least of which is who identifies the ethnicity of these people in the criminal databases. Who says you're Cherokee or Lumbee or black or white? Also, these databases have virtually no data from England, Scotland, Germany, the Netherlands, or any of Europe.

Therefore, you're by default going to match some people from the wrong locations. Unfortunately, people are trying to determine their ancestors locations using this type of testing. In many cases, people are so very desperate to "find out who they are" that they don't fully understand what they are purchasing or seeing as test results.

In Summary: Mitochondrial DNA and Y-DNA tests give you exactly what they say they will for that one line. From these test results, you will know if you do or do not descend from a Native American ancestor for the line tested. You are better off finding appropriate descendants to take these two tests because they give you a positive yes or no for that particular line. The DNAPrint test provides you with some information concerning your ancestry percentage, but only for four categories; Native American, Indo-European, East Asian and Sub-Sahara African. And if your percentage of one or more of the four is below about 15%, your result will be ambiguous.

See American Indian (Continued on page 35)



American Indian (Continued from page 34)

DNAPrint tests are more expensive, and most people are unhappy with the ambiguous nature of the results. The Autosomal / CODIS / Forensic testing is really inappropriate for genealogical testing at this time due to the nature of the data to which it is compared. Therefore; most people should test for Y-DNA and/or mtDNA for themselves and appropriate relatives. For the Y-DNA and mtDNA test results to be valuable, you need to clearly understand which line these tests do and do not represent.

I believe your descendants 50 to 100 years from now will be disappointed when they find your birth certificate, your marriage license, your death certificate and find where you were enumerated in the Census, but fail to find your DNA test results!

R.B. Noles

It is typically a more sophisticated consumer that would even know about the DNAPrint test and the autosomal testing available, unless you just happen to stumble across one of the sometimes unethical Web sites promoting such tests.

I have participants in my projects who have used all four type of tests and view the results just like any other genealogical information -- interesting but inconclusive by themselves. All of this data needs to be evaluated as a whole, fully understanding what each test can and cannot tell you. That's why I ask participants to supply me with their known genealogy, to be evaluated along with and in conjunction with the DNA test results, regardless of which test(s) are obtained.

My concern is that I don't want genetic genealogy testing to be tainted by people not happy with their results, because they didn't understand the potential benefits and the limitations of the available tests.

DNA testing is a very valuable tool when people understand what they are buying and what they are really getting for their money.

ISOGG, the International Society for Genetic Genealogy is an unbiased group (and free) for the education of the masses about genetic genealogy and they provide a good comparison of companies and services available on their Web site (www.isogg.org).

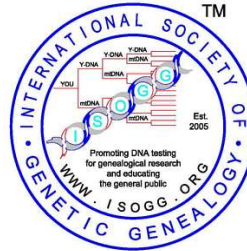

ISOGG does not include unethical companies in their evaluations and their work has always been very good. In addition, they have a success stories section on their Web site that is just plain fun to read. There are several examples of how different kinds of DNA testing can be used to prove and disprove relationships, and how people have done just that.

I hope you will find the above information useful for determining what DNA test you want to purchase.

Finally, I believe your descendants 50 to 100 years from now will be disappointed when they find your birth certificate, your marriage license, your death certificate and find where you were enumerated in the census, but fail to find your DNA test results!

Your test results will probably surprise you, if they don't conform to your preconceived ideas about your heritage.

My Web site for the Lumbee Tribe DNA Project is available via the following link:

http://www.huxford.com/Genetics_Lumbee.htm

Tests for the Lumbee Tribe DNA Project can be ordered via the following link:

https://www.familytreedna.com/surname_join.aspx?code=u33343&special=true&ftdna_ref=335
(no spaces in this link)

